

G. SUBITO® KT for internal profiles

The SUBITO® KT is used for the measurement of internal profiles and internal gear teeth, groove toothings and spline bore hub profiles. The SUBITO® segment deviation ensures high reliability and accuracy. By the interchangeable KT measuring inserts, an extensive range of application can be covered. The ball inserts are fitted with tungsten carbide balls and are screwed in the contact pin and the interchangeable measuring pins. The therefore used tungsten carbide balls are already available from a diameter of 0,5 mm; they are graduated by 0,001 mm and have a diameter tolerance of $\leq 2 \mu\text{m}$. If requested, it is possible to make a calibration certificate for the KT ball inserts. During the oscillation process, the instrument is centred automatically, as the balls are guided prismatically in the profile to be measured. Master pieces or master setting rings are serving for the setting of those comparator gauges.

Accessories

- sets of ball inserts made of t/c (other materials on request)
- measuring depth extensions
- toothed setting master rings

technical data KT

range of application	8 - 510 mm
repeatability	$f_w \leq 0,5 \mu\text{m}$
max. deviation	$f_e \leq 2 \mu\text{m}$
hysteresis	$f_u \leq 2,5 \mu\text{m}$

SELECTION CRITERIA FOR SUBITO® KT

Range of application M	mm	mm	mm	mm	mm
from	8	12	22	55	100
to	12	22	55	250	510
travel s	0,6	0,6	1,0	1,5	1,5
measuring depth MT	100	102	110	177	235
total length L	165	168	204	290	363
tube Ø R	5	5	8	12	18
no. of measuring pins	5	11	9	7	5
no. of increment washers	1	1	2	3	4
extensions	-	-	(1)/16	(3)/50	(5)/70
thread ball insert	M 1,6	M 1,6	M 2,5	M 4	M 4

THE VARIAT



SUBITO® KT

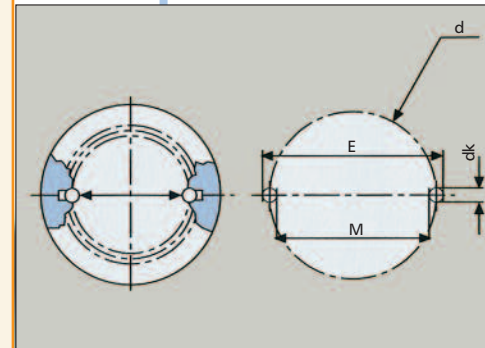

setting dimension for KT

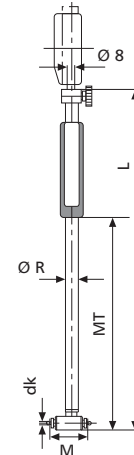

SUBITO® KT