

L. SUBITO® SL for the measurement of bores with boring bar left in the workpiece

If there is an obstruction in the centre of the bore to be measured, a standard measuring instrument cannot be used. This can occur for example if a workpiece is still clamped in the turning machine and the boring bar cannot be moved away for measuring. The range of application of the 4 SL-instrument size goes from 25 to 500 mm. Within the range of application of the instrument, the SL gauge can be adjusted freely by a column for the pre-adjustment of the instrument. The measuring depth extends from 12 mm for the smallest gauge to 30 mm for the largest gauge.

SELECTION CRITERIA FOR SUBITO® SL

Range of application D	mm	mm	mm	mm	mm
from	25	35	100	100	200
up to	70	105	210	280	500
travel s	2,0	3,0	3,5	3,5	3,5
measuring depth MT	12	17,5	30	30	30
front distance	1,8	3,0	4,5	4,5	4,5
total length L min./max.	190/235	212/285	293/403	293/473	610/710
max. boring bar Ø B	45	70	130	130	220
dimension c	17	23	37	37	62
dimension G	160	177	190	190	215
dimension H	7,7	6	10	10	8
min. difference Ø D - Ø B*	6	12	18	18	20

between boring bar and bore wall

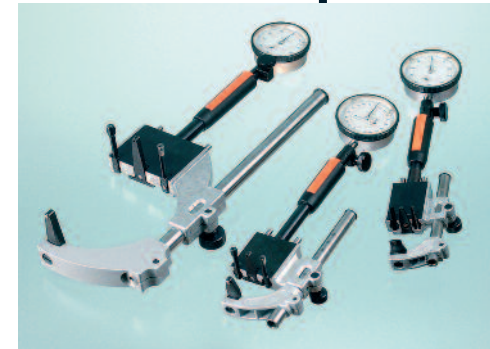

SUBITO® SL

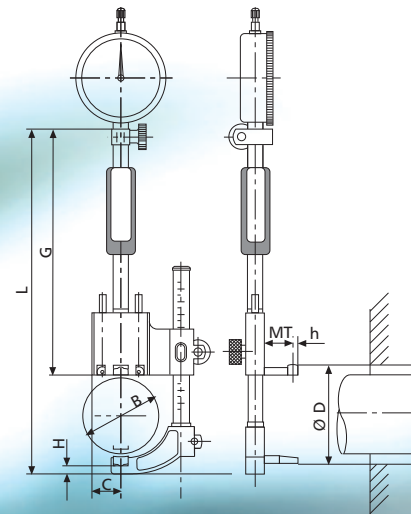

SUBITO® SL