

Digital tool setting instrument MERY E

X = 260mm / Z = 520mm SK40

Product number: 1465102
EAN / GTIN: 4066918055194
Manufacturer number: 30520
Customs code: 90178090
Delivery method: Truck freight
Weight: 30kg

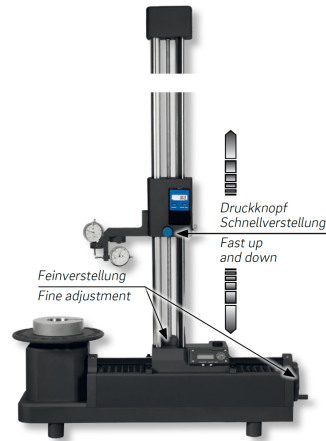

Product description

- Works standard
- Sylvac System
- Measuring and adjusting tools
- Tool holding device rotating
- LCD display, reading 0.01mm
- Precision dial gauges (0.01mm) for X- and Z-axis
- X- and Z-axis with quick adjustment with central push button
- Fine adjustment with hand wheel
- Standard tool holding device SK 40

Delivered with dial gauges

Functions:

- On/Off
- mm/inch commutation
- Zero setting at any position
- \pm Preset function
- Data output Opto

Application:

- contact measurement at the tool edge
- precision guided probes for x- and z-axis
- precision dial gauge s as 0-point indicator
- constant measuring force < 1N to protect the tool edge
- perfect for determination of diameter and length

Technical Data

Size:	X = 260mm / Z = 520mm SK40
Article number:	1465102
Brand:	DEMM
Manufacturer number:	30520
Angle error:	0,03mm
Dimension H:	848mm
Dimension L:	684mm
Execution:	MERY E
Load:	max. 15Kg
Reading:	0,01mm
Tool fitting:	SK40
Working range:	X=260mm / Z=520mm
Weight:	30kg